

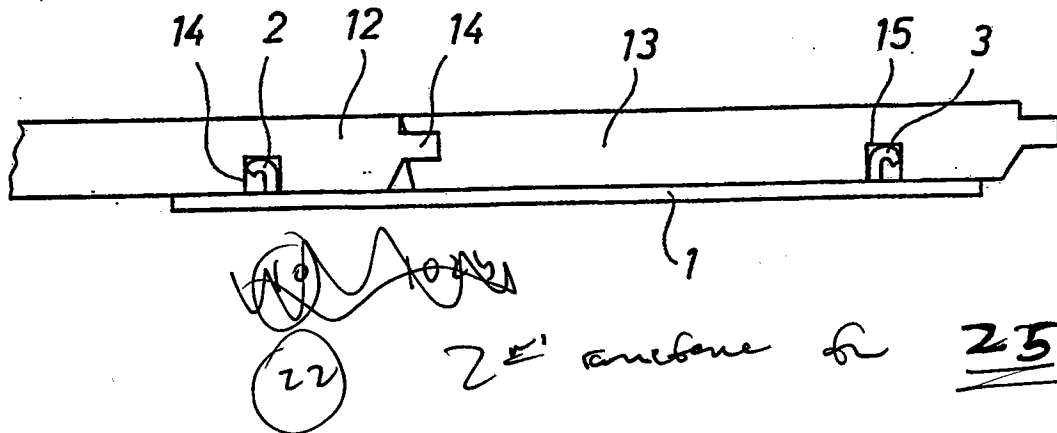

INTERNATIONAL APPLICATION PUBLISHED UNDER THE PATENT COOPERATION TREATY (PCT)

<p>(51) International Patent Classification ⁵ : E04F 15/02</p>	<p>A1</p>	<p>(11) International Publication Number: WO 93/13280 (43) International Publication Date: 8 July 1993 (08.07.93)</p>
<p>(21) International Application Number: PCT/DK92/00394 (22) International Filing Date: 22 December 1992 (22.12.92) (30) Priority data: 2071/91 27 December 1991 (27.12.91) DK (71) Applicant (for all designated States except US): JUNCKERS INDUSTRIER A/S [DK/DK]; Værftsvej, DK-4600 Køge (DK). (72) Inventors; and (75) Inventors/Applicants (for US only) : SKOVBO JØRGENSEN, C., J. [DK/DK]; Billesborgvej 64, DK-4600 Køge (DK). SEPSTRUP, Erik [DK/DK]; Magnolievej 11, DK-4600 Køge (DK). STORM, Hans [DK/DK]; Nordskovvej 7, DK-4681 Herfølge (DK).</p>		<p>(74) Agent: CHAS. HUDE; H.C. Andersens Boulevard 33, DK-1553 Copenhagen V (DK). (81) Designated States: CA, JP, US, European patent (AT, BE, CH, DE, DK, ES, FR, GB, GR, IE, IT, LU, MC, NL, PT, SE). Published With international search report. In English translation (filed in Danish).</p>

(54) Title: A DEVICE FOR JOINING FLOOR BOARDS



(57) Abstract

A device for joining floor boards comprises an elongated, plate-shaped body (1) with legs (2, 3) adapted to engage a longitudinal groove (14, 15) in each of the adjoining floor boards (12, 13). The legs (2, 3) are shaped at a distance from the ends of the plate-shaped body (1) in such a manner that the plate-shaped body (1) supports the boards (12, 13) on each side of the grooves (14 and 15).

FOR THE PURPOSES OF INFORMATION ONLY

Codes used to identify States party to the PCT on the front pages of pamphlets publishing international applications under the PCT.

AT	Austria	FR	France	MR	Mauritania
AU	Australia	GA	Gabon	MW	Malawi
BB	Barbados	GB	United Kingdom	NL	Netherlands
BE	Belgium	GN	Guinea	NO	Norway
BF	Burkina Faso	GR	Greece	NZ	New Zealand
BG	Bulgaria	HU	Hungary	PL	Poland
BJ	Benin	IE	Ireland	PT	Portugal
BR	Brazil	IT	Italy	RO	Romania
CA	Canada	JP	Japan	RU	Russian Federation
CF	Central African Republic	KP	Democratic People's Republic of Korea	SD	Sudan
CG	Congo	KR	Republic of Korea	SE	Sweden
CH	Switzerland	KZ	Kazakhstan	SK	Slovak Republic
CI	Côte d'Ivoire	LJ	Liechtenstein	SN	Senegal
CM	Cameroon	LK	Sri Lanka	SU	Soviet Union
CS	Czechoslovakia	LU	Luxembourg	TD	Chad
CZ	Czech Republic	MC	Monaco	TG	Togo
DE	Germany	MG	Madagascar	UA	Ukraine
DK	Denmark	ML	Mali	US	United States of America
ES	Spain	MN	Mongolia	VN	Viet Nam
FI	Finland				

Title: A device for joining floor boards

Technical Field

5 The invention relates to a device for joining floor boards and comprising an elongated, plate-shaped body with a leg adapted to engage a longitudinal groove in each of the adjoining floor boards.

10 Background Art

Devices for mounting floor boards are known in form of substantially U-shaped clips. The legs of these clips are formed by way of bending and are optionally provided with barbs in such a manner that they are locked in grooves on the bottom side of the floor boards. Such clips are for instance known from EP-PS No. 126,764. The object of the clips is to keep adjoining floor boards together and optionally to press said boards together.

20 As it is a question of relatively thick floor boards of a thickness of from approximately 12 to 22 mm, both the legs of the clips and the grooves receiving said legs can be shaped rather large without strict tolerance standards without acting on the already laid flooring.

25 However, a flooring depends highly on the accuracy of the control of each floor board when subjected to oscillating effects, such as moisture. When it is a question of production of floorings made of relatively thin, solid floor boards of undressed wood and of a thickness of less than about 12 mm, it turned out to be impossible to obtain completely satisfactory results by means of the existing clips. Accordingly, it has only been possible previously to put down such floorings by gluing the boards together or by carrying out a hidden nailing at the tongue/groove connections. Both fastening methods can cause problems when the flooring is subjected to an oscillating moisture of the atmosphere. A low moisture of the atmosphere causes formation of chinks in the

flooring, and a high moisture of the atmosphere has the effect that the flooring has a tendency to bulge up. The thinner the floor board is the faster the moisture in the wood and consequently also the size of the floor board changes or adjusts to the surroundings. Thin floorings have therefore necessitated development of a device eliminating these drawbacks.

Description of the Invention

10

The object of the invention is therefore to provide a device suited for use in connection with thin floorings, especially floorings made of solid undressed wood and subjected to a varying moisture of the atmosphere, and where said device allows a simple and fast laying of the flooring.

20

The device according to the invention is characterised in that the legs are shaped at a distance from the ends of the plate-shaped body.

25

The resulting flooring can be mounted in a relatively easy and fast manner at the same time as it is reliable, which is due to the fact that the devices are fixedly and non-tiltably arranged in each groove, said device comprising members abutting the bottom side of the floor board on each side of the groove. The device is advantageous both during the laying procedure and in the already laid flooring. During the laying procedure the device is fastened by one leg thereof being arranged in the groove of one board where it is secured in such a manner that it cannot be moved, i.e. it cannot be turned or tilted away from the bottom side of the floor board. As a result, the device does not tend to fall out during the laying of the board in the desired horizontal position so as to be ready for being joined with yet another board. The groove of the other board is easily caused to engage the second leg of the device while the boards are

30

35

pushed together by means of the tongue/groove connection. If the device had been able to tilt relative to the first groove it engaged, it would have fallen out easily and thereby destroyed the rim of the relatively
5 accurately shaped groove and optionally also the fine shaping tolerance of the leg. Then it would often be necessary to replace the device in question by a new device and arrange said new device on a new location relative to the groove. The connection between the
10 device according to the invention and each board is thus capable of absorbing the torque in both directions about an axis of rotation extending along the groove of each board. As a result, a reliable keeping together of the boards of the already laid flooring is ensured.

15

According to the invention the legs of the device may be shaped by bending two webs projecting away from one another, said webs resulting from a punching out of a substantially I-shaped opening in each end of the plate-
20 shaped body, where the two transverse legs of the I extend in the longitudinal direction of the plate-shaped body. The resulting device is particularly simple with a reliable, symmetrical structure.

25 The bent webs may according to the invention be of a substantially hook-shaped cross section, whereby a shape is obtained which ensures that the legs are easily inserted in a groove and are locked therein.

30 Finally according to the invention, the bent webs may be bent substantially perpendicular from the plate-shaped body at a distance from the location where the webs extend from the plate-shaped body and project into the punched out portion. In this manner it is ensured that
35 the device is provided with a particularly accurate, rectangular transition from the plate-shaped portion to each leg with a relatively small radius of curvature with the result that the plate-shaped portion of the

device is automatically positioned so as closely to abut the bottom side of the boards.

Brief Description of the Drawing

5

The invention is described in greater detail below with reference to the accompanying drawing, in which

Fig. 1 is a top view of a preferred embodiment of a
10 device according to the invention,

Fig. 2 is a sectional view on a larger scale taken along the line II-II of Fig. 1, and

15 Fig. 3 illustrates a portion of a flooring laid by means of the device of Figs. 1 and 2.

Best Mode for Carrying Out the Invention

20 The device shown in the drawing comprises an elongated, plate-shaped body 1 of a substantially rectangular shape. The device comprises an upwardly projecting leg 2, 3 at each end, said legs being shaped integral with the plate-shaped body 1 by way of bending.

25

The legs 2 and 3 are produced in connection with their respective punched out I- or H-shaped opening 4 and 5, respectively. These openings 4 and 5 are shaped symmetrically about the longitudinal central axis of the
30 plate-shaped body 1 a short distance from each end of said plate-shaped body. The parallel legs of the I or the H extend parallel to the longitudinal symmetrical axis of the plate-shaped body 1. The legs 2 and 3 are shaped by the punched out web 6 and 7, respectively,
35 being bent. The webs 6 and 7 project from the side of the opening 4, 5 adjacent the centre of the plate-shaped body 1 and into said opening. As a result each leg 2, 3 is bent out from the plane of the plate-shaped body 1 a

short distance from the connection of the web 6, 7 with the plate-shaped body 1 in such a manner that a short portion 8 and 9, respectively, of the web is flushing with the plate-shaped body 1. The radius of curvature of each leg 2, 3 at the transition 10 to the plate-shaped body 1 can therefore be shaped relatively small.

Each leg 2 and 3 is of a substantially hook-shaped form with the result that a sharp edge 11 is formed. The sharp edge ensures a good engagement of the leg and the board in question.

The legs 2 and 3 are, as mentioned, shaped on the side of the openings 4 and 5 adjacent the centre of the plate-shaped body 1 while being simultaneously bent in such a manner that the sharp edge 11 on the hook-shaped leg 2 and 3 faces away from the centre of the plate-shaped body 1. In this manner the legs 2 and 3 provide a particularly good resistance against the tendency of the floor boards to expand at the same time as the sharp edge 11 has a tendency to bite itself into the board in question by cutting into the wood on the same side as the portion of the plate-shaped body which extends from the legs 2, 3 to the ends. In this manner a self-increasing resistance is obtained against a turning or tilting of the device 1 relative to each board.

Fig. 3 illustrates two abutting floor boards 12 and 13 engaging one another by means of a groove/tongue connection 14. Each board 12 and 13 comprises a longitudinal groove 14 and 15, respectively, on the bottom side, said grooves being manufactured with an accurate position relative and parallel to the longitudinal rims of the board 12 and 13. The grooves 14 and 15 are simultaneously manufactured with relatively fine tolerances.

As illustrated, the boards 12 and 13 are mounted on the bottom side by means of a device of the type shown in

figs. 1 and 2, where the plate-shaped body 1 extends transverse to the groove/tongue connection 14 of the boards 12 and 13 with a leg 2, 3 received in their respective groove 14, 15. It appears clearly, that the
5 plate-shaped body extends to each side relative to each groove 14, 15 and is thereby abuttingly arranged against the boards 12 and 13 on both sides of the grooves 14 and 15.

10 The device according to the invention is preferably made of plate-shaped spring steel of a thickness of about 0.75 mm, a width of 20 mm, and a length of 135 mm. The height of the legs relative to the plate-shaped body 1 is suitably of a dimension 3.1 mm, whereas their mutual
15 distance is 111 mm. The distance between the side of the legs 2, 3 perpendicular to the plate-shaped body 1 adjacent the centre and the associated sharp edge 11 is advantageously about 2.5 mm. Such a device is suited for use in connection with 8 mm thick solid boards of a
20 width of 113.9 mm. The associated grooves are suitably 2.35 mm wide and 3.5 mm deep. Boards of a width of 129.0 mm involve the use of devices made of spring steel of a length of 150 mm. The mutual distance of the legs is 126.5 mm. All the remaining dimensions are the same as
25 above.

The invention has been described with reference to a preferred embodiment of the invention. Many modifications may be carried out without thereby deviating from
30 the scope of the invention. Each leg may for instance be shaped as a double leg adjacent both longitudinal sides of the plate-shaped body with an intermediary portion extending as an extension past the legs to the ends of the plate-shaped body 1.

Claims.

1. A device for joining floor boards and comprising an elongated, plate-shaped body with a leg adapted to engage a longitudinal groove in each of the adjoining floor boards, characterized in that the legs (2, 3) are shaped at a distance from the ends of the plate-shaped body (1).
- 10 2. A device as claimed in claim 1, characterized in that the legs (2, 3) are shaped by bending two webs (6, 7) projecting away from one another, said webs resulting from a punching out of a substantially I-shaped opening (4, 5) in each end of the plate-shaped body (1), where the two transverse legs of the I extend
15 in the longitudinal direction of the plate-shaped body (1).
3. A device as claimed in claim 1 or 2, characterized
20 in that the bent webs (6, 7) are of a substantially hook-shaped cross section.
4. A device as claimed in claim 3, characterized
25 in that the bent webs (6, 7) are bent substantially perpendicular from the plate-shaped body at a distance from the location where the webs (6, 7) extend from the plate-shaped body (1) and project into the punched out portion.

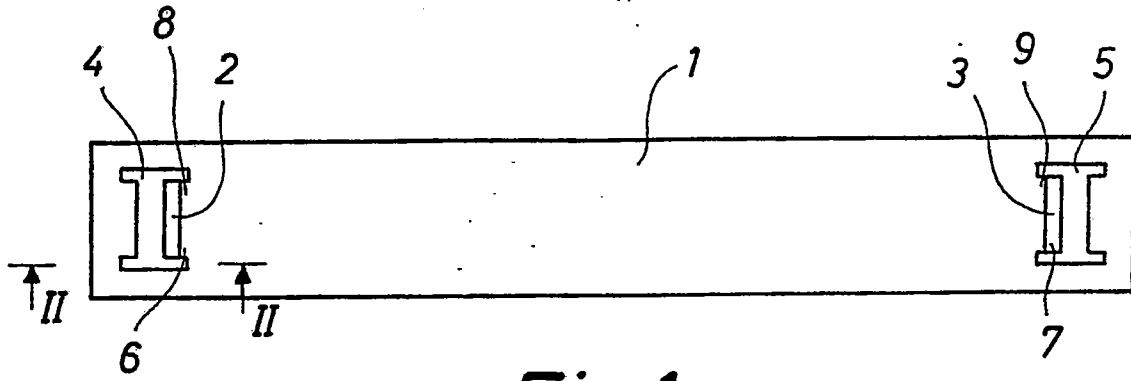

Fig. 1

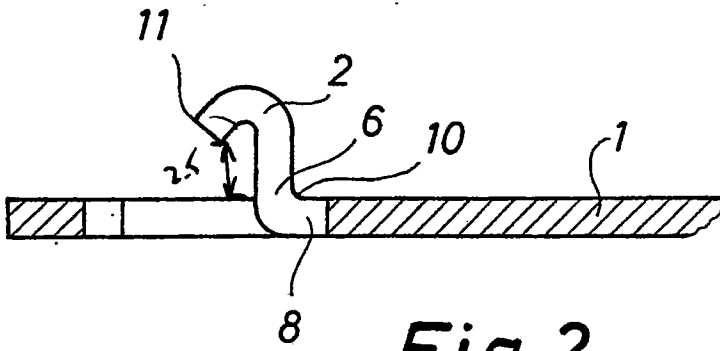

Fig. 2

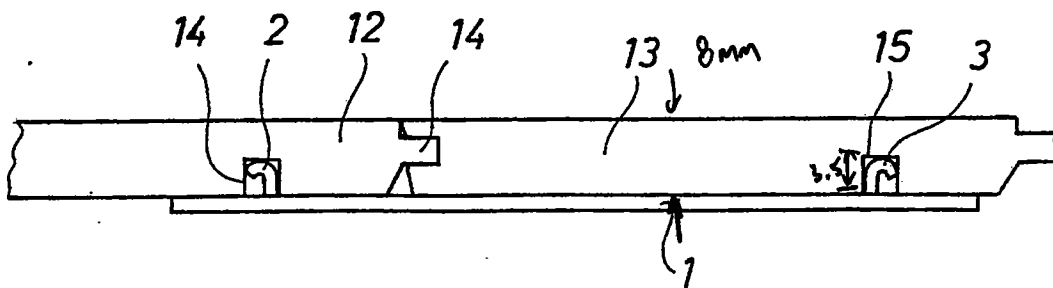

Fig. 3

A. CLASSIFICATION OF SUBJECT MATTER

IPC5: E04F 15/02

According to International Patent Classification (IPC) or to both national classification and IPC

B. FIELDS SEARCHED

Minimum documentation searched (classification system followed by classification symbols)

IPC5: E04F

Documentation searched other than minimum documentation to the extent that such documents are included in the fields searched

SE,DK,FI,NO classes as above

Electronic data base consulted during the international search (name of data base and, where practicable, search terms used)

C. DOCUMENTS CONSIDERED TO BE RELEVANT

Category*	Citation of document, with indication, where appropriate, of the relevant passages	Relevant to claim No.
X	SE, B, 372051 (RY AB), 9 December 1974 (09.12.74), figure 3, claims 1,2 --	1
X	WO, A1, 8402155 (CARLSSON, J. ET AL), 7 June 1984 (07.06.84), abstract, detail 3 --	1
Y	--	2-4
X	WO, A1, 8707667 (WOLFF, D.), 17 December 1987 (17.12.87), figures 3,6, abstract --	1
Y	--	2-4

 Further documents are listed in the continuation of Box C.
 See patent family annex.

* Special categories of cited documents:

- "A" document defining the general state of the art which is not considered to be of particular relevance
- "E" earlier document but published on or after the international filing date
- "L" document which may throw doubts on priority claim(s) or which is cited to establish the publication date of another citation or other special reason (as specified)
- "O" document referring to an oral disclosure, use, exhibition or other means
- "P" document published prior to the international filing date but later than the priority date claimed

"T" later document published after the international filing date or priority date and not in conflict with the application but cited to understand the principle or theory underlying the invention

"X" document of particular relevance: the claimed invention cannot be considered novel or cannot be considered to involve an inventive step when the document is taken alone

"Y" document of particular relevance: the claimed invention cannot be considered to involve an inventive step when the document is combined with one or more other such documents, such combination being obvious to a person skilled in the art

"&" document member of the same patent family

Date of the actual completion of the international search

19 March 1993

Date of mailing of the international search report

30 -03- 1993

 Name and mailing address of the ISA/
 Swedish Patent Office
 Box 5055, S-102 42 STOCKHOLM

Authorized officer

Örjan Nylund

INTERNATIONAL SEARCH REPORT

International application No.
PCT/DK 92/00394

C (Continuation). DOCUMENTS CONSIDERED TO BE RELEVANT

Category*	Citation of document, with indication, where appropriate, of the relevant passages	Relevant to claim No.
X	DE, A1, 2616077 (HEWENER, H.J.), 27 October 1977 (27.10.77), figure 1	1
Y	----- -----	2-4

INTERNATIONAL SEARCH REPORT
Information on patent family members

26/02/93

International application No.

PCT/DK 92/00394

Patent document cited in search report	Publication date	Patent family member(s)	Publication date
SE-B- 372051	09/12/74	NONE	
WO-A1- 8402155	07/06/84	EP-A,B- 0126764 SE-T3- 0126764	05/12/84
WO-A1- 8707667	17/12/87	DE-A- 3619287	10/12/87
DE-A1- 2616077	27/10/77	NONE	